

Product Line Brochure

SonicWALL® **ECLASS**

SONICWALL®

PROTECTION AT THE SPEED OF BUSINESS™

SonicWALL E-Class Series

Historically, enterprise security solutions have been technologically limited, notoriously expensive or difficult to deploy and use. SonicWALL® E-Class represents a new generation of comprehensive solutions for Network Security, Secure Remote Access, Email Security, and Policy and Management. Engineered to drive the cost and complexity out of running a secure enterprise-class network, E-Class solutions deliver elegant simplicity and unparalleled value. The E-Class portfolio extends SonicWALL's commitment to providing premium solutions at a significantly lower total cost of ownership, through purpose-built solutions designed to address the unique requirements of mid- to large-size organizations.

SonicWALL E-Class includes:

- **SonicWALL E-Class Network Security Appliance (NSA)**
- **SonicWALL Aventail E-Class Secure Remote Access (SRA)**
- **SonicWALL E-Class Email Security**
- **SonicWALL Global Management System (GMS)**

SonicWALL Protected Network

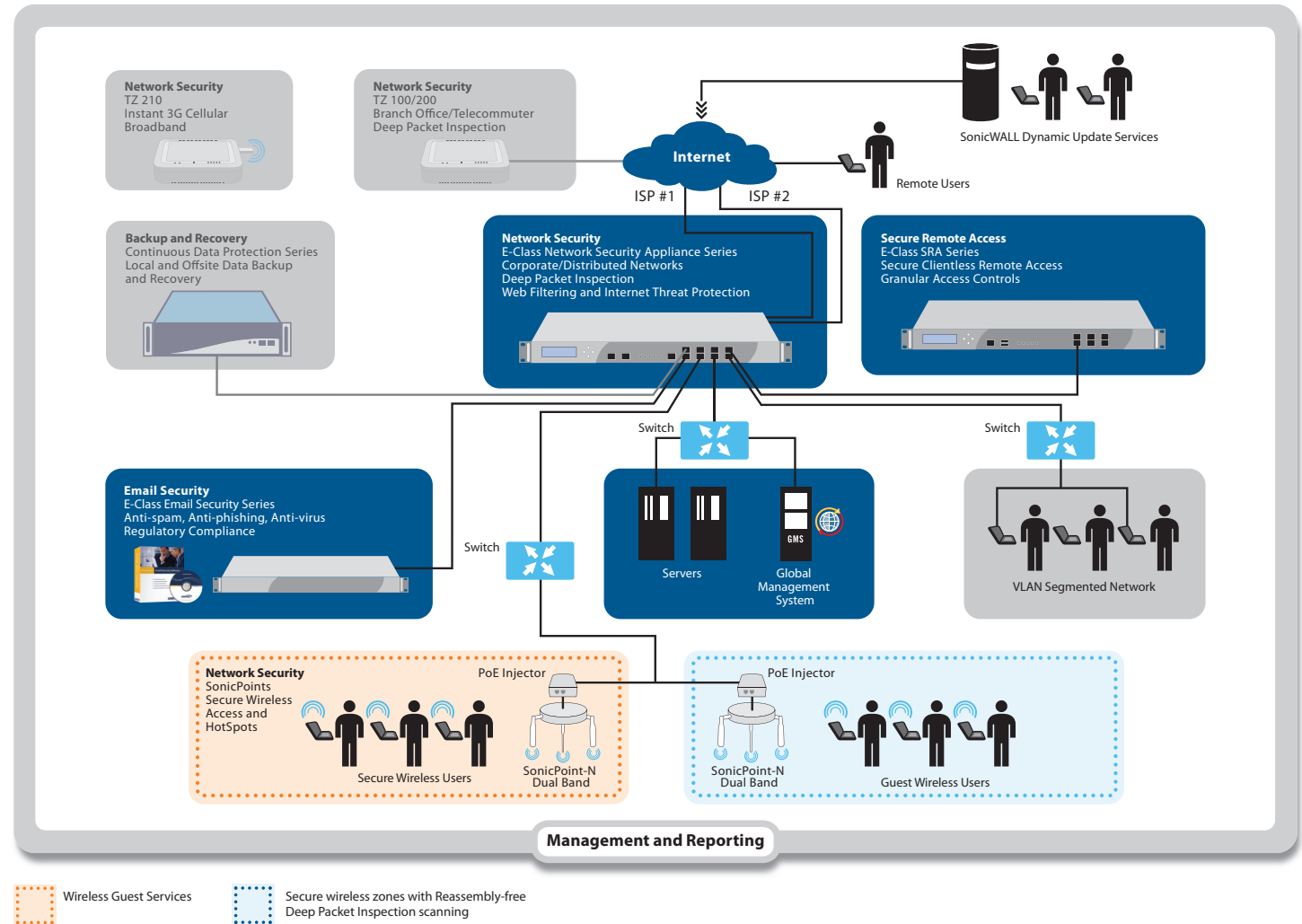

Introduction

The Evolution of Enterprise Network Security

While breakthrough advances in real-time communications and mobility have extended business access to mission-critical network resources, they also make securing those resources more complex. The traditional “internal” LAN is becoming obsolete, as laptops, smartphones and other mobile devices move in and out of the perimeter, and attacks can originate from either side. Leveraging these evolving vulnerabilities, financially-motivated criminal attackers have unleashed ultra-sophisticated threats, increasing the risk of losing data, bandwidth, productivity and corporate funds. Traditional decentralized point products add hidden costs in limited policy inspection and control, cumbersome integration, ineffective traffic scanning, increased false positives, and lower performance. These limited, one-size-fits-all products fail in attempting to harden an ever-expanding and fluid network perimeter, instead of tightening security around the application data center and the communications that deliver these resources to the end user.

The E-Class Alternative: Defend, Control and Manage

The new challenge for enterprise IT is to establish a distributed network that is easy and cost-effective to defend, control and manage. By focusing technology investment on easy yet comprehensive solutions that **defend, control and manage** enterprise-class networks, E-Class solutions deliver exemplary protection with lower administrative overhead, for a greater overall return.

Defend

Challenge

- Profit-driven, multi-prong real-time attacks on the entire data stream that exploit new-found vulnerabilities
- Potential security vulnerabilities in unmanaged remote and mobile endpoint devices
- Inbound and outbound e-mail threats and content liability exposure

SonicWALL E-Class Solution

- E-Class NSA combines unified threat protection with real-time deep packet inspection
- E-Class SRA interrogates remote and mobile endpoint devices to enforce security requirements before authorizing accesses to resources
- E-Class Email Security protects against spam, viruses, phishing attacks and unauthorized content

Control

Challenge

- The majority of bandwidth is used by the minority of users
- Inappropriate Internet use that drains productivity and introduces threats
- Data leakage that creates substantial liabilities and financial implications
- Collaborative and mobile access from an expanding range of users, devices and locations
- Support demand for varied forms of user- and department-specific e-mail-based communications

SonicWALL E-Class Solution

- E-Class NSA employs multi-core processors for maximum throughput with bandwidth control for greater efficiency and application use. E-Class NSA delivers gateway anti-virus, anti-spyware and intrusion prevention at gigabit speed.
- E-Class NSA Content Filtering Service blocks inappropriate Internet use
- E-Class Email Security stops outbound e-mail leaks of confidential information
- E-Class SRA applies granular policy control over all leading platforms from all leading and mobile devices
- E-Class Email Security provides extensive and granular end-user capabilities while retaining complete IT control over e-mail

Manage

Challenge

- Increasing business dependence on technology and real-time access to information
- Networks expanding over a wider array of technology platforms and geographic locations
- Meet and prove regulatory compliance
- Overwhelmed IT resources that could otherwise be applied to more pressing needs

SonicWALL E-Class Solution

- E-Class GMS can centrally deploy, configure and manage thousands of SonicWALL network security appliances
- Reporting delivers real-time and trend analysis for business and compliance needs
- Compliance reporting gives administrators the capability to generate and view reports that fulfill compliance requirements
- E-Class solutions are engineered to be easily and centrally managed, backed by SonicWALL's 24x7 enterprise-class support staff, and dynamically enhanced by SonicWALL Global Response Intelligence Defense (GRID) collaborative network for gathering and sharing security intelligence across all product platforms

Enterprise-class Network Security: E-Class Network Security Appliance



The SonicWALL E-Class Network Security Appliance (NSA) Series offers the industry's first multi-core unified threat management solutions for enterprise-class, deep-packet protection security that won't slow down throughput.

E-Class NSA E7500, E6500 and E5500 appliances are engineered to be the most scalable, high-performance and

reliable multi-function threat appliances in their class, protecting organizations against a vast spectrum of network attacks at unprecedented speed. E-Class NSAs delivers gateway anti-virus, anti-spyware and intrusion prevention featuring an extensive array of advanced networking and configuration options that integrate seamlessly into high-performance network environments. The powerful NSA Application Firewall feature-set delivers precise control and inspection over network traffic and applications.

Enterprise-class Secure Remote Access: SonicWALL Aventail E-Class SRA



SonicWALL Aventail E-Class SSL VPNs offer the mobile workforce access to key applications and resources from anywhere, with unmatched granular security. **E-Class SRA EX7000, EX6000 and EX-750** appliances are engineered to detect the identity and integrity of the endpoint device, protect enterprise

resources with granular policy control and connect authorized users easily to mission-critical applications over all leading platforms from all leading devices. Easy to use and easy to control, E-Class SRA provides a single enterprise-class solution for remote access, extranets, mobility, wireless, disaster recovery, policy control and Network Access Control (NAC).

"The new E-Class product offering demonstrates SonicWALL's continued investment and commitment in making the industry's easiest to manage, ultra high-speed security appliances. SonicWALL is taking its product innovation and expertise from the SMB market and applying it to the enterprise market by delivering a solution that uniquely addresses the needs of large, distributed networks."

Tom McDougall, President and CEO at High Point Networks

Enterprise-class Communications Protection: E-Class Email Security



SonicWALL E-Class Email Security delivers highly scalable and effective inbound and outbound e-mail protection, while reducing administrative overhead. Available as a software or appliance solution, SonicWALL **E-Class Email Security** boosts productivity by stopping spam, viruses and phishing; supports regulatory compliance and corporate governance

initiatives by detecting and blocking e-mail data leaks; and adapts to any network configuration, whether centralized or highly distributed, through its proven split mode architecture. SonicWALL E-Class Email Security appliances include the ES6000 and the high-availability ES8300 models.

Enterprise-class Policy And Management: E-Class GMS

SonicWALL E-Class Global Management Solution (GMS) delivers the power of real-time policy-based monitoring and reporting, with the flexibility to centrally deploy, configure and manage thousands of SonicWALL network security appliances. E-Class GMS eases management of distributed enterprise networks with dispersed branch offices and remote sites, without the costs, complexity and risks associated with disparate software bundles. E-Class GMS reduces staffing requirements, speeds up deployments and lowers the cost of managing security services.

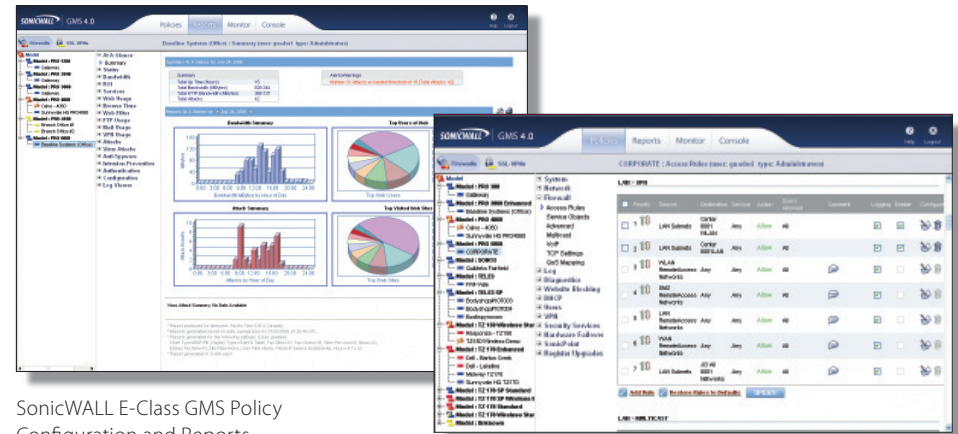

SonicWALL E-Class GMS Policy Configuration and Reports

Enterprise-class Solutions: The E-Class Series

	Network Security	Secure Remote Access	Email Security	Policy and Management
Threat Protection	<ul style="list-style-type: none"> Layered approach, integrating gateway anti-virus, anti-spyware and intrusion prevention Re-assembly-free deep packet inspection (DPI) Matches all downloaded, e-mailed and compressed files against an extensive, continuously updated signature database, scanning all files in real time Enterprise-class performance levels that do not compromise network speed 	<ul style="list-style-type: none"> Robust End Point Control (EPC) interrogation of Windows, Windows Mobile, Macintosh and Linux endpoint environments EPC identifies the endpoint and confirms policy criteria (like anti-virus updates or certificate-based watermarks) at user login, as well as at administrator-defined intervals, to ensure ongoing endpoint integrity SonicWALL Aventail E-Class SRA solutions supports Vasco, RSA, Active Directory, LDAP, RADIUS and ACE authentication, as well as One-Time Password (OTP) generation for two-factor authentication 	<ul style="list-style-type: none"> Protects organizations from spam, phishing, virus, DHA and DoS e-mail-based attacks The SonicWALL GRID Network ensures that this protection is always up-to-date through the real-time monitoring of worldwide threat activity, thereby maintaining protection at the highest level possible SonicWALL GRID Anti-Virus™ leverages SonicWALL's anti-virus and anti-spyware technology to deliver anti-virus and anti-spyware protection 	<ul style="list-style-type: none"> Provides the tools to manage security policies and services throughout a large-scale, multiple-policy enterprise or service provider environment A flexible, powerful and intuitive solution that centrally manages and rapidly deploys thousands of SonicWALL appliances and security policy configurations
Scalability	<ul style="list-style-type: none"> Highly redundant security and connectivity platform purpose-built for high-speed internal and external network protection, virtual private network (VPN) implementations and deployment flexibility The multi-core architecture paralleled performance design offers ultra high-speed threat protection and flexible scalability 	<ul style="list-style-type: none"> Rapid set-up and Web-based deployment of secure remote access to branch locations, home PCs, kiosks, PDAs, smartphones and unmanaged devices over wired and wireless networks Models supporting up to 2,000 concurrent users, featuring clustering for high availability (HA) using externally-sourced or internal integrated load balancing SonicWALL Aventail E-Class SRA solutions are easier than ever to deploy and manage with a more intuitive Setup Wizard, simplified policy objects and streamlined activity monitoring 	<ul style="list-style-type: none"> Scalable to any size organization, SonicWALL Email Security can utilize a Split Mode configuration that has been proven to handle up to 100 million messages a day. Multiple systems are managed centrally through one "control center," which allows for unlimited scalability with minimal additional management overhead per additional system. Multi-system configurations can be software-based, appliance-based, or a combination of software and appliances. Supports multiple LDAP servers and an unlimited number of domains, and allows flexible policy enforcement by user, group, domain, LDAP server or all system users. 	<ul style="list-style-type: none"> Allows creation of SonicWALL ViewPoint® reports that can be customized to meet compliance with internal and external regulatory mandates such as PCI, SOX, HIPAA or GLBA
Mobility	<ul style="list-style-type: none"> Functions as a secure wireless switch and controller that automatically detects and configures SonicWALL SonicPoints™ wireless access points for secure remote access in distributed network environments 	<ul style="list-style-type: none"> Connect Mobile™ can provide access to a broad range of client/server and Web-based applications from Windows Mobile-powered devices Access control and EPC ensure that the user and device is fully authorized before allowing access IT can add the security of mobile two-factor authentication or use client certificates as a device watermark to revoke access if the device is lost or stolen 	<ul style="list-style-type: none"> Extend e-mail security to corporate e-mail received and sent over smartphones or PDA devices 	
Compliance	<ul style="list-style-type: none"> Content Filtering Service (CFS) provides organizations with greater control to block inappropriate, illegal and dangerous Web content, using a dynamic rating and caching architecture To ensure the highest levels of protection CFS is configured and controlled from the E-Class NSA, eliminating costly dedicated filtering servers 	<ul style="list-style-type: none"> Provide the granular policy controls needed to comply with Sarbanes-Oxley, HIPAA, Basel 2 and other regulatory requirements, while still providing remote access from unmanaged or managed devices, even during business disruptions Enhanced user monitoring features streamline auditing and troubleshooting of current and historical user activity. Administrators can easily view or filter activity by user, time, throughput, realm, community, zone, agents or IP address. 	<ul style="list-style-type: none"> Lets organizations create and enforce specific policies designed to ensure the highest level of compliance possible Specifically, E-Class Email Security will actively prevent violation of compliance terms, prevent leaks of confidential data and private and sensitive information, and enforce all e-mail usage policies 	<ul style="list-style-type: none"> Allows creation of SonicWALL ViewPoint® reports that can be customized to meet compliance with internal and external regulatory mandates such as PCI, SOX, HIPAA or GLBA
Productivity	<ul style="list-style-type: none"> CFS helps restrict employees or other users from accessing Web sites that drain productivity by promoting wasteful Web surfing or file sharing, thereby limiting bandwidth spikes and reducing opportunities for malicious infection 	<ul style="list-style-type: none"> Enhances productivity by providing easy access to more applications from more environments than any other secure access solution The organization can extend access and improve productivity to users leveraging mobile devices, providing a universal solution for remote access control, instead of only a niche solution just for mobile device e-mail access Broader cross-platform support extends Connect Tunnel EPC and Advanced EPC functionality to Windows, Macintosh and Linux 	<ul style="list-style-type: none"> Enhances productivity with unsurpassed end-user controls such as an integrated Junk button for Outlook® giving users to greater control of their inbox, relieving frustration and reducing calls to the IT help desk Simplifies deployment and management Updates of the latest threat outbreaks are automatically received and deployed every five minutes Management reports can be scheduled and e-mailed 	<ul style="list-style-type: none"> SonicWALL GMS streamlines security policy management and deployment, which minimizes administration overhead and lowers the total cost of ownership
Disaster Recovery/ Business Continuity	<ul style="list-style-type: none"> Redundancy features for high availability (HA). Feature options include active/passive failover redundancy, and dual hot-swappable fans and power supplies 	<ul style="list-style-type: none"> Offer an intelligent, reliable solution for enterprise-class disaster recovery, whether triggered by a catastrophic event like a hurricane, or by something as simple as a regional power outage Employees can gain access from IT-managed devices via Connect Tunnel, or from non-managed devices via the Workplace portal Can be deployed in multiple geographic locations using policy replication Spike License pack allows temporary increases in SonicWALL Aventail E-Class SSL VPN license capacity in the event of a large scale business disruption Can be deployed in conjunction with SonicWALL Continuous Backup and Recovery (CDP) for comprehensive business continuity protection 	<ul style="list-style-type: none"> Available as a software solution, ideal for SAN deployments, or an appliance solution, with up to 2-5 times the storage of competitive appliances, SonicWALL Email Security can be an integral part of an organization's e-mail storage and retention policies. 	

Deployment Scenarios

Central-site/Distributed

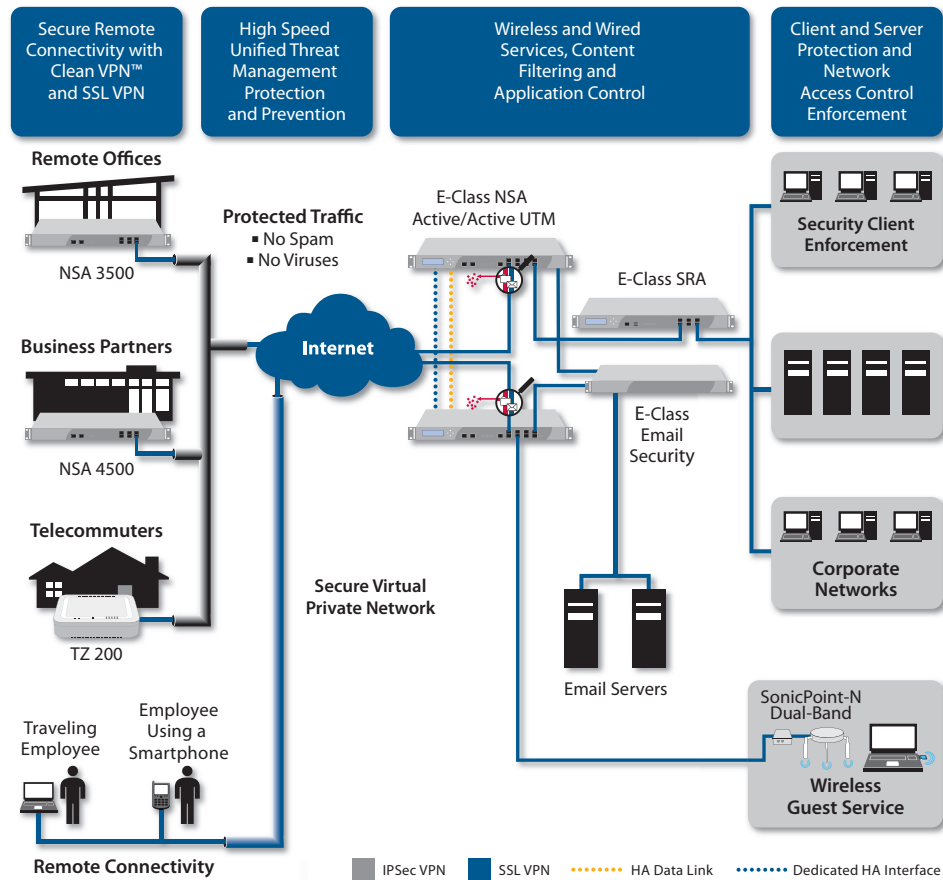

SonicWALL E-Class solutions provide a high-speed scalable platform to meet the requirements of enterprise deployments such as network central-site gateways. Available as software or appliances, E-Class E-mail Security can be deployed on a single device, or in Split Mode, utilizing multiple devices, all managed centrally via a Control Center. Connected units, known as Remote Analyzers, sit at the perimeter, offering flexible scalability for high e-mail volume or distributed e-mail environments. The E-Class Series includes innovative SonicWALL Clean VPN™ technology, which integrates network security and VPN technology to provide a defense-in-depth combination of high-performance real-time network security with granular application and endpoint remote access control. Additionally, SonicWALL Aventail Smart Tunneling™ provides granular bidirectional access control for back-connect applications like VoIP and remote help desk. The addition of E-Class GMS means administrators can configure and manage their secure remote access solution and their network security solution all from a single management interface.

Campus

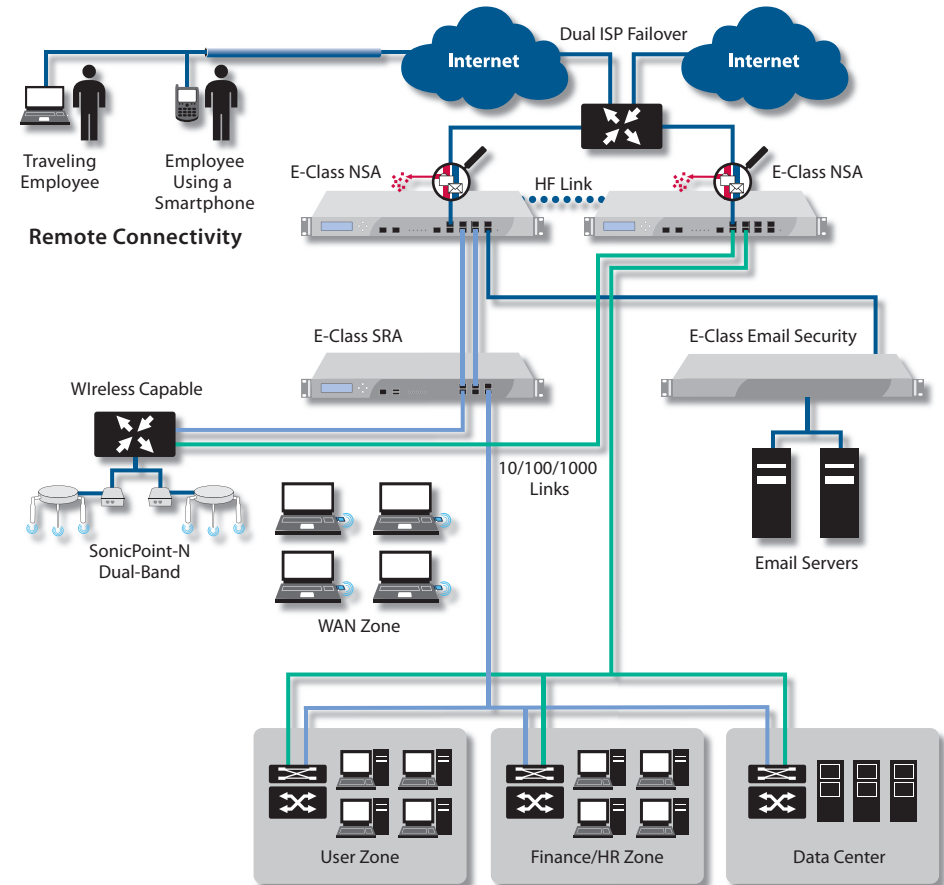

In campus environments, SonicWALL E-Class provides administrators with total control over zone-level policy and resource access for both wired and wireless users. Additionally, E-Class secure remote access can securely connect laptops PDAs, smartphones and other IT-managed or unmanaged devices over wired and wireless campus networks environments.

Remote Deployment

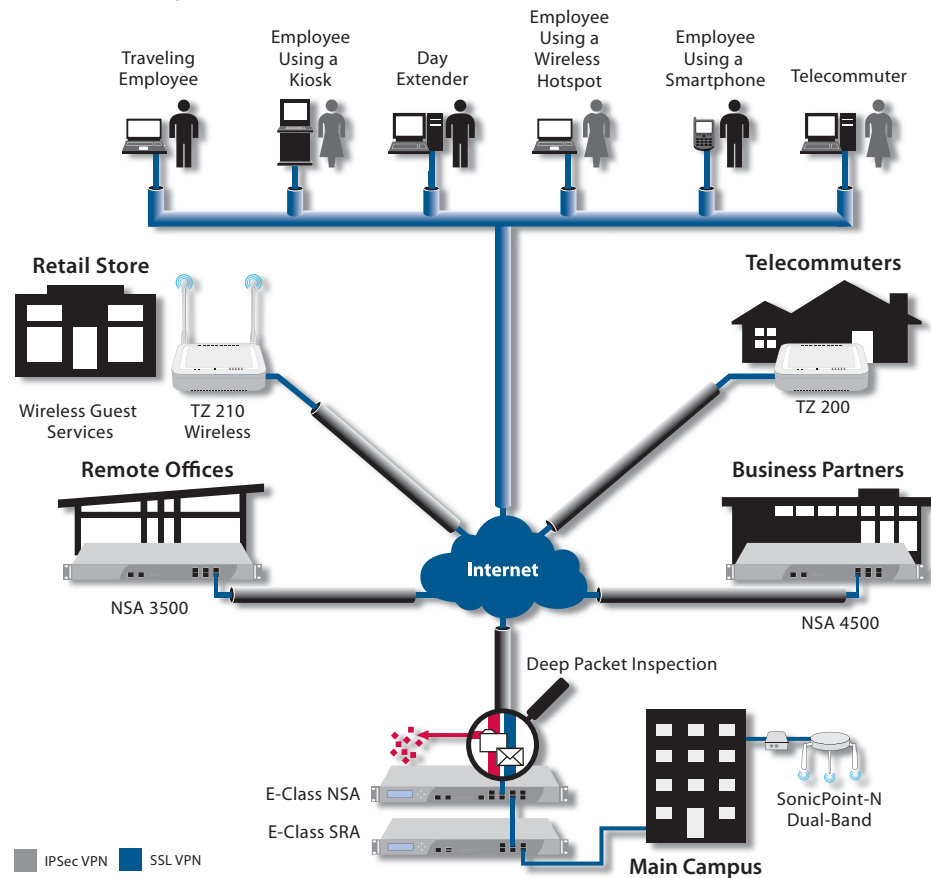

E-Class SRA technology provides transparent access to network resources from any network environment or device. It can provide authorized employees, partners, suppliers and customers with extranet access to key resources. Integrated IPsec VPN on the network security solution is a secure alternative for site-to-site connectivity to a branch office or remote location. E-Class SRA offers Connect Tunnel Service Edition for secure automated application-to-application connectivity, such as regularly-scheduled branch-to-headquarters data uploads.

In-line Deployment

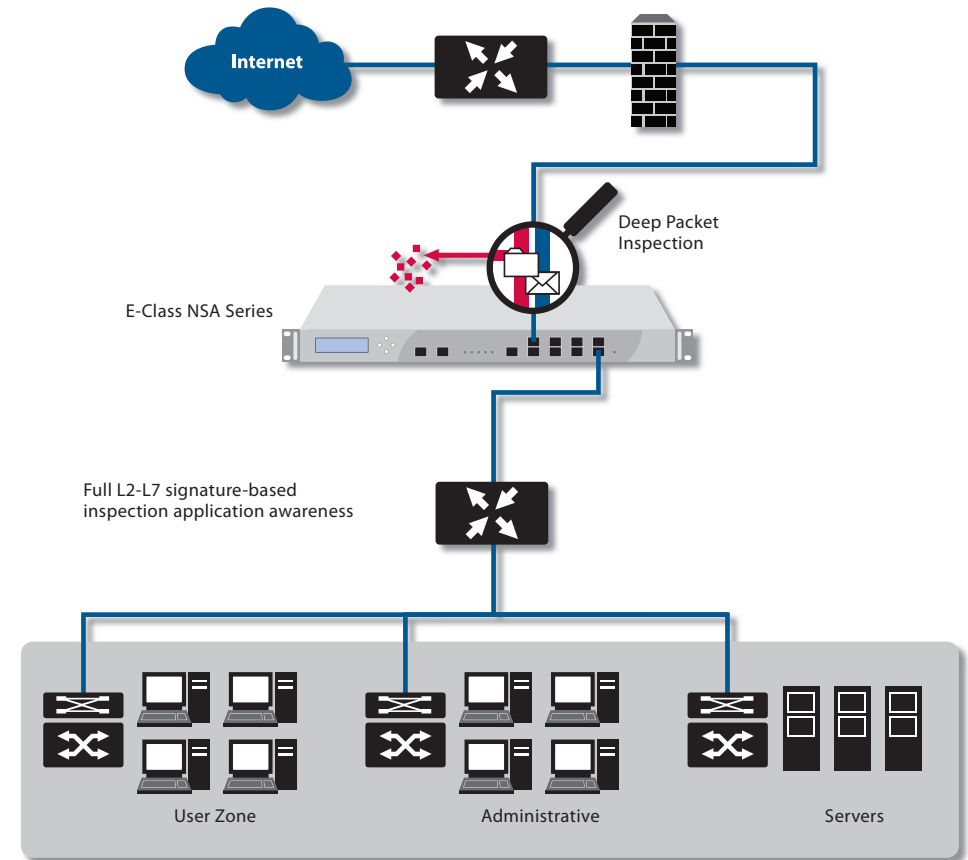

E-Class network security can be deployed in Layer 2 bridge mode to provide inline intrusion detection and prevention, add security to network segments or business units and simplify layered security

Leadership

Since 1991, SonicWALL has provided tens of millions of users with easy-to-use, superior quality, and high-performance appliances and services, hailed by industry publications and analysts such as Gartner, InfoWorld, PC Magazine, Network World and SC Magazine.

SonicWALL has extended its leadership from the small to mid-sized market to the enterprise, by investing in additional development and acquiring world-class solutions for secure remote access (Aventail and EnKoo), backup and recovery (Lasso Logic), and e-mail security (MailFrontier).

SonicWALL maintains strategic relationships with industry-leading partners and resellers, with over 15,000 qualified, customer-focused resellers and distributors delivering our award-winning solutions worldwide. Offering comprehensive 24x7 support, consulting and design services, technical training and certification courses, SonicWALL helps organizations of all sizes to more effectively plan, deploy and manage their security infrastructures.

SonicWALL continually dedicates its ongoing vision and resources to keep our customers' network security and data protection solutions ahead of ever-evolving threats. SonicWALL employs the industry's finest team of security and data protection professionals, devoted to providing innovative solutions for integrated network security, secure remote access, Web and e-mail security, backup and recovery, and policy and management.

Conclusion

In the past, vendors emerged to provide single-point solutions in response to single-point threats as they arose. Security was perceived as highly complex and esoteric, requiring an overly complicated and expensive response. In recent years, however, the network security market has matured dramatically, eliminating the perceived mystery. IT is increasingly open to simpler, well engineered, yet cost-effective solutions. In selecting security solutions today, IT has an opportunity to escape the clutches of premium-priced vendors without compromising performance or value.

Building upon its solid success in distributed enterprise environments, SonicWALL is committed to providing organizations of all sizes with solutions of greater value at a significantly lower total cost of ownership through purpose-built solutions designed to address the unique requirements of each segment. The culmination of this commitment is the E-Class Series of enterprise-class solutions for network security, e-mail protection and secure remote access, and policy and management. SonicWALL E-Class solutions offer outstanding protection and performance while delivering elegant simplicity and unparalleled value.

For more information on SonicWALL E-Class solutions, please visit www.sonicwall.com/e-class.

“We’re looking forward to working with SonicWALL on bringing their latest products to market based on SonicWALL’s proven track record for product innovation and commitment to creating an outstanding experience for its customers, we anticipate high demand from the enterprise marketplace for the new E-Class product offering.”

James Carter, CTO at The Integration Works

SonicWALL, Inc.

2001 Logic Drive
San Jose, CA 95124

T +1 408.745.9600
F +1 408.745.9300

www.sonicwall.com

SONICWALL®

PROTECTION AT THE SPEED OF BUSINESS™